

**Original Article****Simulation of the Effect of a Baffle Structure on Membrane Efficiency Using Computational Fluid Dynamics during the Clarification of Pomegranate Juice**Reza Sharifanfar¹, Hossein Mirsaedghazi^{2*}, Ali Fadavi², Mohammad Hossein Kianmehr¹

1. Department of Agrotechnology, College of Abouraihan, University of Tehran, Pakdasht, Iran.

2. Dept. of Food Technology Engineering, College of Abouraihan, University of Tehran, Pakdasht, Iran.

Received: June 2016

Accepted: August 2016

ABSTRACT

Background and Objectives: Pomegranate juice (PJ) contains large particles that stick to evaporator walls causing off flavors in the concentrate due to burning. Microfiltration is used to clarify PJ. Fouling is a limiting phenomenon that can prevent the industrialization of membrane clarification. Changes in the geometry of the membrane module such as using baffles are useful to decrease this problem. Computational fluid dynamics (CFD) is a powerful numerical tool used in modeling membrane processing.

Materials and Methods: The effect of baffle geometry on the efficiency of membrane clarification of pomegranate juice in a flat-sheet module was simulated using computational fluid dynamics (CFD). The geometry of the membrane unit was plotted and meshed with Gambit software, and was solved using FLUENT software. A two-dimensional double-precision method at steady state was selected to simulate the membrane process. The convective terms were discretized with a standard first-order upwind scheme in computational solution. The RNG k- ϵ model was used due to its high accuracy in eddy flows with a low Reynolds number. The effects on the process performance of the number of baffles, their angle and the distance between the baffles and the membrane surface were evaluated.

Results: The results showed that the configuration with the feed-channel height of 2 cm, the baffle angle of 90° and the distance between the membrane surface and baffles of 2 mm had maximum permeate flux.

Conclusions: Reducing the distance between the baffles and the membrane surface increased the permeate flux due to create an eddy flow near the membrane surface in the flat-sheet module and reduced the total and cake-layer resistances.

Keywords: Baffle, Computational fluid dynamics, Juice, Membrane, Pomegranate

Introduction

Pomegranate juice (*Punicagranatum* L., Punicaceae), which has many nutritional benefits, contains large particles in its original state. Such particles may stick to evaporator walls, causing off flavors in the concentrate due to burning (1).

Microfiltration (MF) is a pressure-driven process used to clarify fruit juices (2, 3). Fouling is a limiting phenomenon that can prevent the industrialization of membrane clarification due to increased time and costs (4-6). Changes in the geometry of the membrane module (e.g. using baffles) can decrease fouling in

membrane processing by causing increased turbulence on the membrane surface.

Computational fluid dynamics (CFD) is a powerful numerical tool, which is becoming more commonly used to simulate and predict food processes such as drying, sterilization and mixing (7-9). It can also be used to model membrane processing. Pak et al. (10) modeled water treatment in porous membranes using CFD. They studied the effects of geometrical dimension, required membrane surface area, Reynolds number and fouling on process performance in membrane treatment. Ahmed et al. (11) employed

CFD to simulate tubular membranes equipped with baffles oriented in different directions. They evaluated the effects of local parameters such as stream functions, velocity, static pressure, shear stress, kinetic energy and dissipation energy on the membrane surface using CFD. Jafarkhani et al. (12) used a three-dimensional CFD method to simulate the fluid flow in a tubular membrane module equipped with semi-circular baffles, examining geometrical parameters like the ratio of pitch to baffle diameter, and baffle angle. Liu et al. (13) applied CFD to simulate central and wall baffles inserted in a tubular membrane channel. Rahimi et al. (14) predicted the permeate flux in the membrane treatment of water using CFD, and investigated the effects of transmembrane pressure and mass flow rate on the permeate flux.

Although the effect of baffles on the efficiency of membrane processing in membrane tubes has been widely investigated, the effect of plate baffles on the efficiency of membrane clarification of fruit juices in flat-sheet microfiltration units has not been studied. The current work simulated the effect of baffles on the membrane clarification of pomegranate juice in flat-sheet modules.

Materials and Methods

Module geometry: The geometrical structure of the membrane module was plotted and meshed in Gambit software using a two-dimensional coordinate system. The plate-and-frame module was 150 mm long and 80 mm wide. The membrane-module channel's height was adjusted at three heights: 1, 1.5 and 2 cm. Some geometrical parameters of baffles, including the number of baffles (distance between baffles), baffle angle, and distance between the baffles and the membrane surface, were investigated. Five angles (30, 45, 90, 135, and 150°) were selected to evaluate the effect of the baffle angle on the process efficiency.

Two distances between the baffles and the membrane surface (2 and 5 mm) were selected to evaluate the effect of shear stress in the membrane surface on the process performance. Configurations using 6, 8 and 12 baffles were selected to study the effect of distance between the baffles on permeate flux.

Definition of boundary conditions in Gambit: The following boundary conditions were selected in the Gambit software:

- The entrance of feed into the membrane module was defined as velocity inlet.
- The exit of retentate from the feed channel was defined as pressure outlet.

- The exit of permeate from the membrane module was defined as pressure outlet.
- The membrane was defined as a porous jump.
- The baffles and other walls were defined as well.

Problem-solving: FLUENT software (version 6.2, FLUENT Inc., New Hampshire, USA), which uses a finite-volume method, was used to simulate the baffle-equipped membrane module. A two-dimensional double-precision method at steady state was selected. The convective terms were discretized by a standard first-order upwind scheme in the computational solution.

Pomegranate juice was defined as a fluid with density of 1060 kgm⁻³ and viscosity of 1.7 × 10⁻³ kgm⁻¹s⁻¹. The convergence dimensionless criteria were adjusted on 10⁻³. In all cases, the pressure of retentate and permeate was adjusted on 0.5 and 0 bar, respectively, and the inlet feed velocity was adjusted on 0.5 ms⁻¹.

Porous jump in FLUENT was defined with three parameters: face permeability, porous-medium thickness, and pressure-jump coefficient.

Face permeability was calculated according to Eq.1:

$$\alpha = \frac{D_p^2 \varepsilon^2}{150 (1-\varepsilon)^2} \quad (1)$$

Where, D_p is the mean particle diameter of pomegranate juice (m) and ε is the membrane void. The calculated face permeability was 4.3949 × 10⁻¹⁴ m².

A mixed cellulose ester (MCE) membrane (Millipore, USA) was used in this study. The thickness of the porous medium was 150 μm.

The pressure-jump coefficient was calculated according to Eq. 2:

$$C_2 = \frac{3.5 (1-\varepsilon)}{D_p \varepsilon^2} \quad (2)$$

The calculated pressure jump coefficient was 35872576.18 m⁻¹ (15).

Development of turbulent mode: The pressure gradient across the membrane is the driving force in microfiltration. The Darcy model was used to determine the permeate flux as follows:

$$J = \frac{1}{A} \frac{dV}{dt} = \frac{\Delta P}{\mu (R_m + R_c)} \quad (3)$$

Where, ΔP , μ , R_m and R_c are transmembrane pressure, viscosity, membrane resistance and cake resistance, respectively (14).

Turbulent regimes in fluids flow are specified with the flow and the statistical properties of their fluctuations. Considering the time-averaged properties such as mean velocities, mean pressure, mean stress and the time-dependent Navier-Stokes

equation leads to the use of the time-average Navier-Stokes equation (14).

Turbulent viscosity can be calculated with several turbulent models, including the mixing length, standard k - ε , RNG k - ε , Reynolds stress and algebraic stress models (13). The RNG k - ε model has engineering applications, and was used here due to its accuracy in describing eddy flows with low Reynolds numbers. It also uses less CPU time than other models, and its form is simpler than that of the standard k - ε model (14).

According to the RNG k - ε model, the turbulent viscosity was calculated as below:

$$\mu_t = \rho C_k \frac{k^2}{\varepsilon} \quad (4)$$

Where, k is kinetic energy and ε is turbulent dissipation.

Verification of the simulated model: Pomegranate juice was clarified with the laboratory-scale membrane unit in bath mode to verify the simulated model (Fig. 1). The feed was pumped from the feed tank to the plate-and-frame membrane module using a rotary van pump (PROCON, Series 2, Milano, Italy). The permeate was collected in the permeate tank,

which was on a digital balance to measure its flux, and the retentate was recycled to the feed tank. A coupled transmitter (WIKA, type ECO-1, Klingenberg, Germany) and inverter (LS, model sv015ic5-1f, Korea) were used to adjust constant trans-membrane pressure in different feed-flow rates, and to adjust the feed-flow rates for different pressures. Hydrophilic mixed cellulose ester (MSE) flat-sheet membrane with a pore size of $0.22 \mu\text{m}$ and an active area of 78 cm^2 (Millipore, Billerica, MA, USA) was employed to clarify the pomegranate juice.

Microfiltration was performed with water after the clarification of pomegranate juice to calculate the total fouling resistance (R_t, m^{-1}) according to Eq. 5.

$$R_t = \frac{1}{\mu_w L_p^p} \quad (5)$$

Where, μ_w is the viscosity of pure water (pa.s) and L_p^p is the hydraulic permeability of membrane after juice treatment, which was determined as follows:

$$L_p^1 = \frac{J_w^1}{\Delta P} \quad (6)$$

Where, J_w^1 ($\text{m}^3/\text{m}^2\text{s}$) is the water permeate flux after juice clarification and ΔP is the transmembrane pressure (pa).

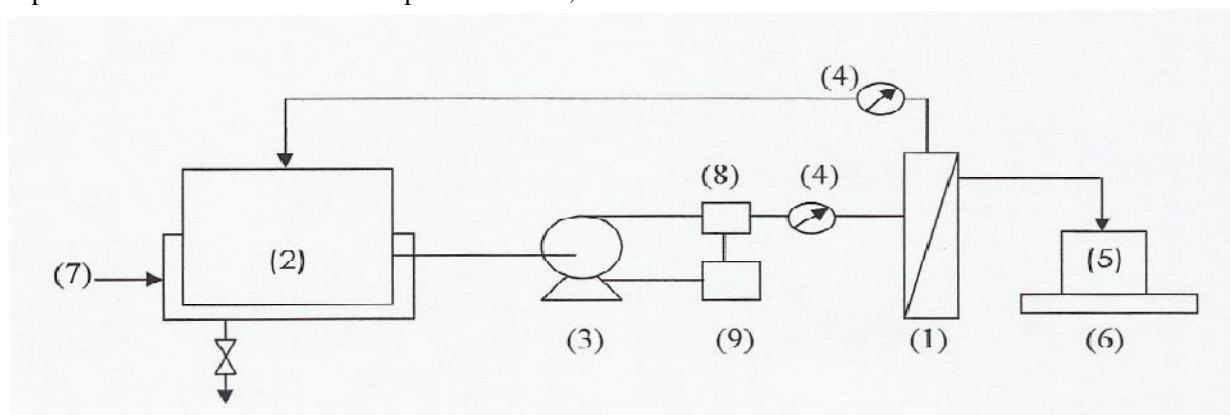

Fig. 1. Plate and frame membrane unit: (1) membrane, (2) feed vessel, (3) centrifugal pump, (4) pressure meter, (5) permeate tank, (6) balance, (7) water flow, (8) transmitter, and (9) inverter.

Results

Effect of distance between the baffles and the membrane surface on the permeate flux: Baffles were designed at five angles (30° , 45° , 90° , 135° and 150°), three channel heights (1, 1.5 and 2 cm) and two distances between the baffles and the membrane surface (2 and 5 mm) to evaluate the effect of baffles on the volumetric flow rate of permeate during the membrane clarification of pomegranate juice. This section describes the results for six baffles spaced at 2 cm.

The results showed that the configuration with a 2 cm feed-channel height, a baffle angle of 90° and 2 mm distance between the membrane surface and the baffles had the most permeate flux, and the membrane module with a channel height of 1.5 cm, a baffle angle of 135° and 2 mm distance from the membrane surface had the second most permeate flux (Table 1). In contrast, decreasing the distance between the baffles and the membrane surface increased the volumetric flow rate of the permeate (Table 1).

Table 1. Effect of the geometrical characteristics of baffles on the volumetric flow rate of permeate during the membrane clarification of pomegranate juice

	Channel height of 1cm		Channel height of 1.5cm		Channel height of 2cm	
	5mm	2mm	5mm	2mm	5mm	2mm
30°	0.0013906*	0.0014934	0.0014129	0.0015528	0.0014066	0.0015053
45°	0.0014192	0.0014958	0.0014129	0.0015192	0.001467	0.0015281
90°	0.0014284	0.0015325	0.0014811	0.001604	0.0015205	<u>0.0016676</u>
135°	0.0013952	0.0015542	0.0014902	<u>0.00165</u>	0.0015102	0.0015376
150°	0.0013826	0.0015158	0.0014457	0.0015621	0.0013412	0.0013549

* Data were reported in m^3s^{-1} .

Evaluation of the velocity magnitude on the membrane surface showed that the feed velocity extensively increased at the baffles due to high shear stress on the membrane surface (Fig. 2). In contrast, the feed velocity extensively increased on the membrane surface with a reduction of the distance between the baffles and the membrane surface (Fig.2).

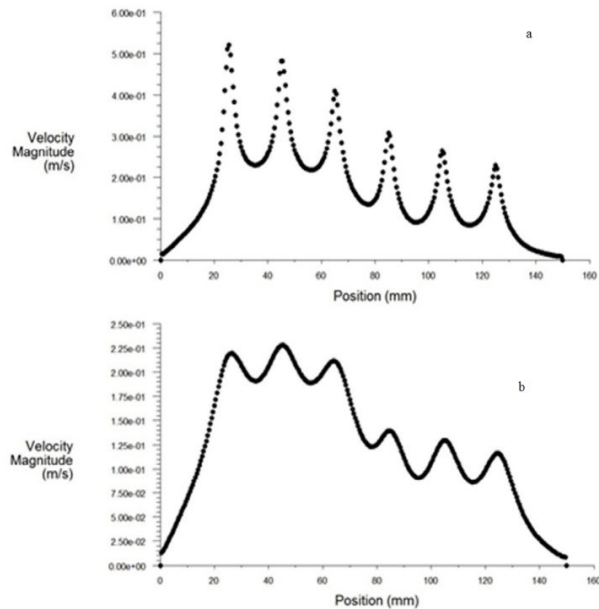

Fig. 2. Velocity magnitude on membrane surface in baffled module with channel height of 2 cm, baffle angle of 90° and different distances between baffles and membrane surface (a: 2 mm, b: 5 mm).

Evaluation of the counter of feed flow in the feed channel showed that where the distance between the baffles and the membrane surface was 5 mm, the feed flow was denser than when the distance was 2 mm; however, in both configurations, the feed flow was produced on the total surface of the membrane (Fig.3).

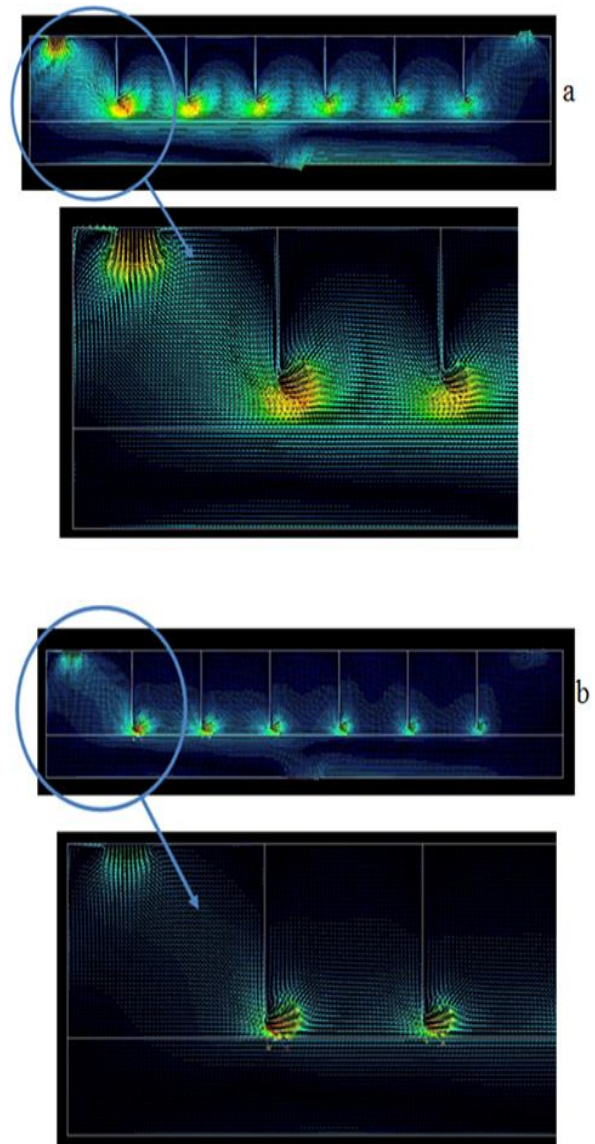

Fig. 3. Counter of feed flow over membrane surface with different distances between baffles and membrane surface (a: 5 mm, b: 2 mm).

Fig. 4 shows the velocity contours of the baffled module with a channel height of 2 cm and a baffle angle of 90° . As expected, when the baffles were 2 mm from the membrane surface, turbulent flow on the membrane surface was more than when the distance was 5 mm. In both configurations, feed velocity between the baffle edge and the membrane surface decreased from the feed entrance toward the retentate exit (Figs. 2 and 4).

Evaluation of the pressure contour in the membrane setup showed that the pressure was reduced after each baffle due to eddy flow on the baffle edges near the membrane surface (Fig. 5). The decrease in the static pressure after each baffle in the baffle-equipped module with 2 mm distance between the baffles and the membrane surface was more than its decrease in the module with 5 mm distance between the baffles and the membrane surface (Fig. 5). This phenomenon

can reduce the energy of the system during the filtration process.

Effect of the number of baffles on the permeate flux: Different baffle geometries with two baffle distances (1.5 and 2 cm) and two baffle angles (90° and 135°) were simulated with maximum permeate flux to investigate the effect of distance between the baffles. The results revealed that the most permeate flux was in the membrane module with six baffles (2 cm distance between baffles), a channel height of 2 cm and a baffle angle of 90° . Increasing the baffle number reduced the volumetric flow rate of the permeate (Table 2). This fact was confirmed with the velocity and static-pressure contours, which showed that increasing the number of baffles can reduce the energy in the microfiltration process. The reduction of pressure and velocity when the number of baffles was increased had a negative effect on the permeate flux (Figs. 6 and 7).

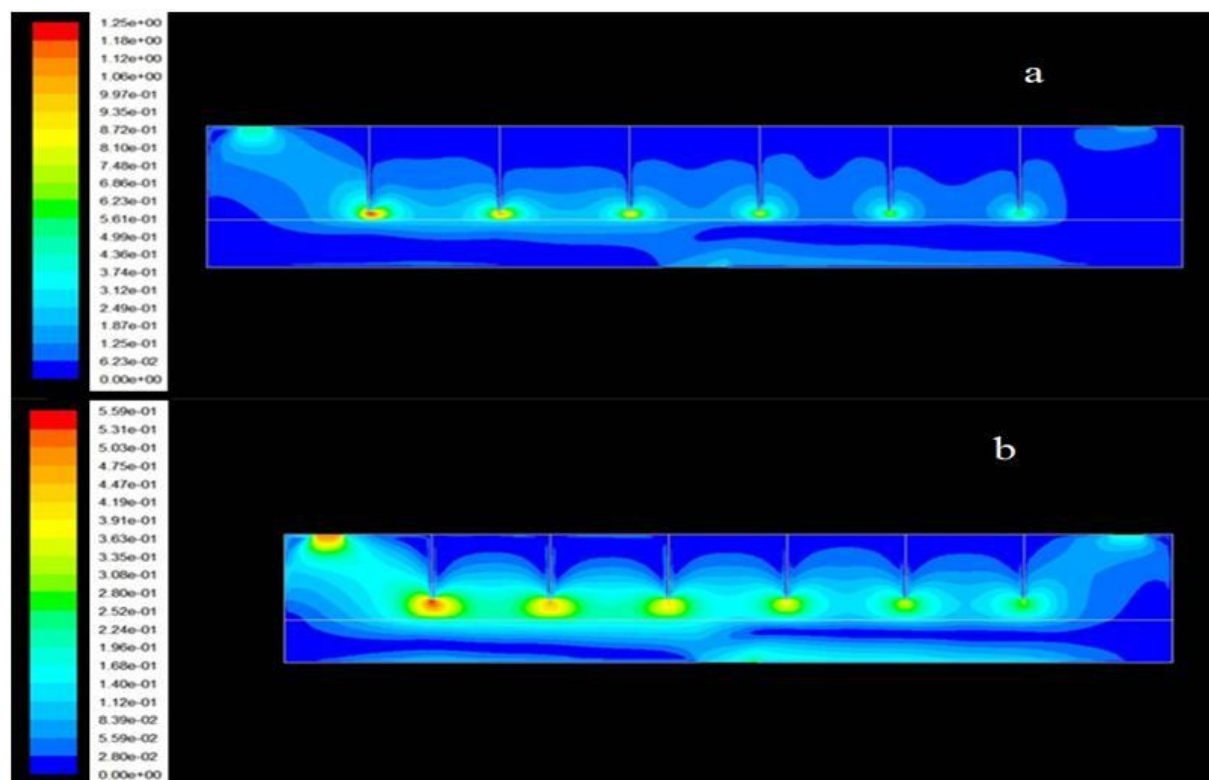

Fig. 4. Velocity contour in baffled module with channel height of 2 cm, baffle angle of 90° and 2 mm distance between baffles and membrane surface.

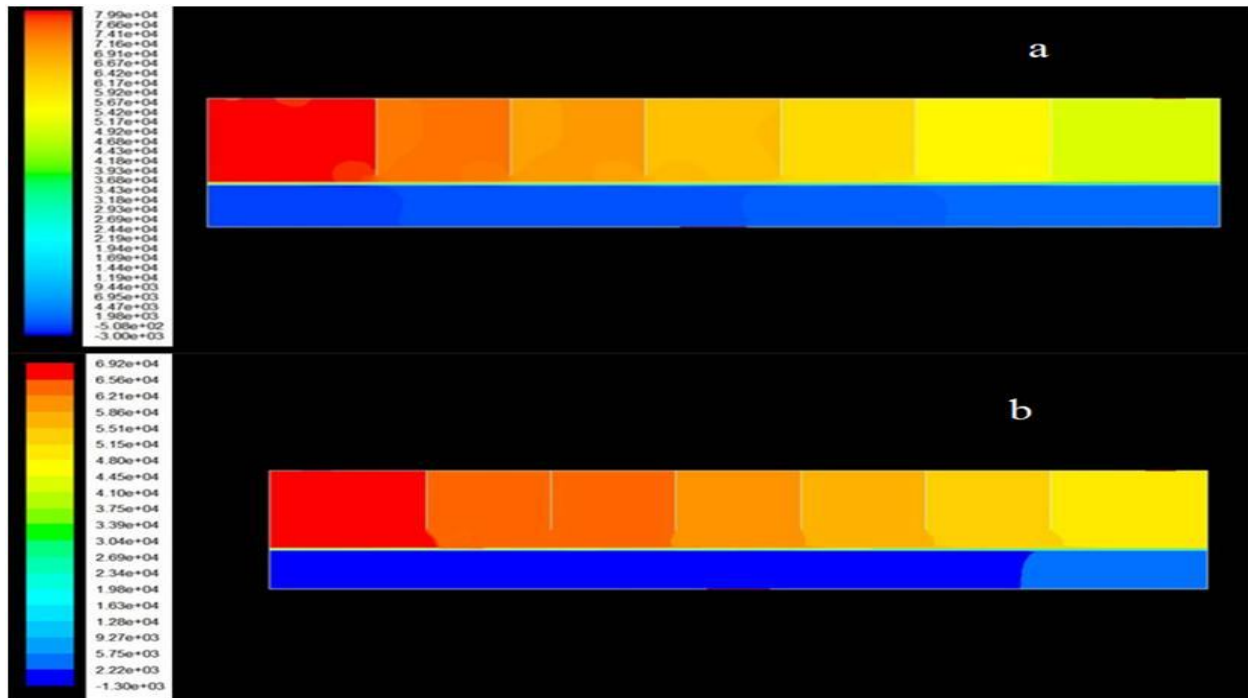

Fig. 5. Static pressure contour of baffled module with channel height of 2 cm, baffle angle of 90° and different distances between baffles and membrane surface (a: 2 mm, b: 5 mm).

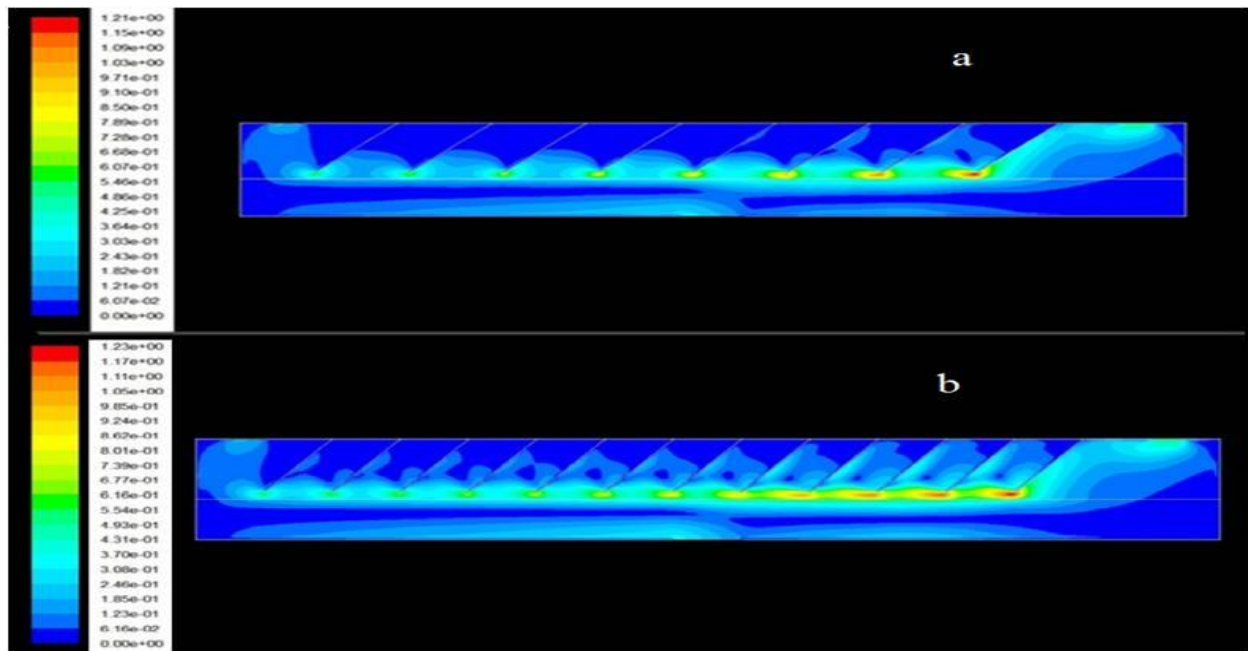

Fig. 6. Velocity contour in baffle-equipped module with 2 cm channel height, 135° baffle angle and 2 mm distance between baffle and membrane surface (a: 8 baffles, b: 12 baffles).

Verification of simulated data: Pomegranate juice was clarified with microfiltration in both a baffle-equipped and a non-baffle equipped membrane module, and total fouling resistance was calculated after juice processing. It was observed that the total fouling resistance in the membrane module without baffles was $1.63 \times 10^{13} \text{ m}^{-1}$; however, its value in the

baffle-equipped membrane unit was $1.27 \times 10^{13} \text{ m}^{-1}$. Reduction of the fouling resistance using baffles in the membrane unit was also confirmed by the images of the membranes after the clarification of pomegranate juice, which showed that formation of a cake layer on the membrane surface and under the baffles was less than at other areas (Fig. 8).

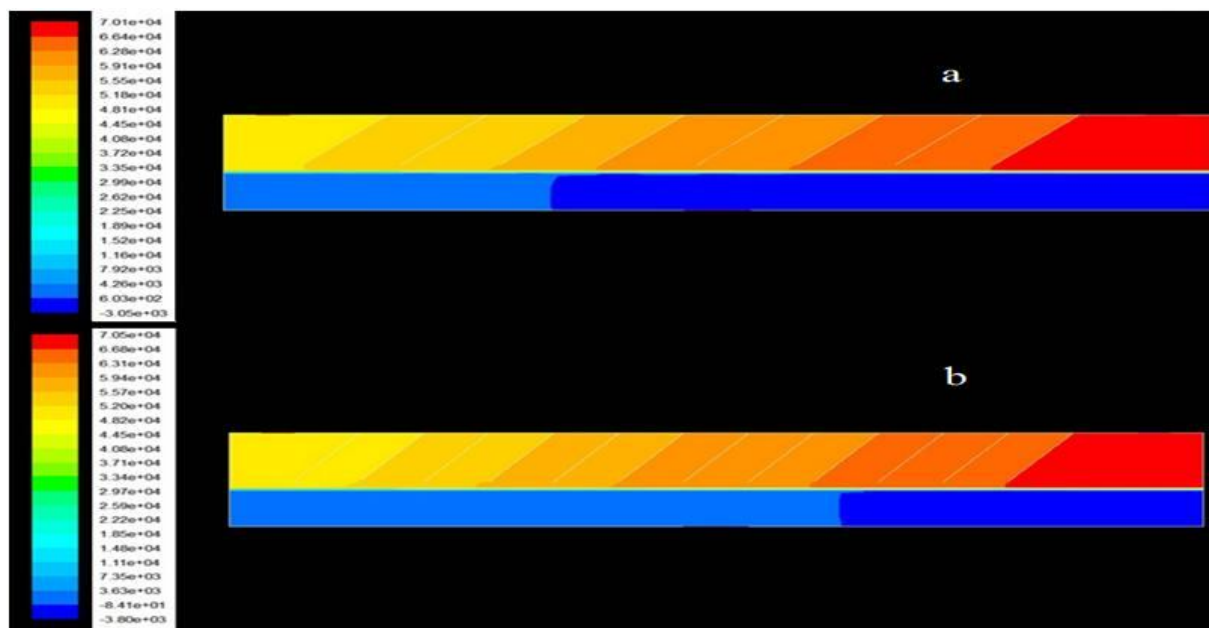

Fig.7. Static pressure contour of baffle-equipped module with 2 cm channel height, 135° baffle angle and 2 mm distance between baffle and membrane surface (a: 8 baffles, b: 12 baffles).

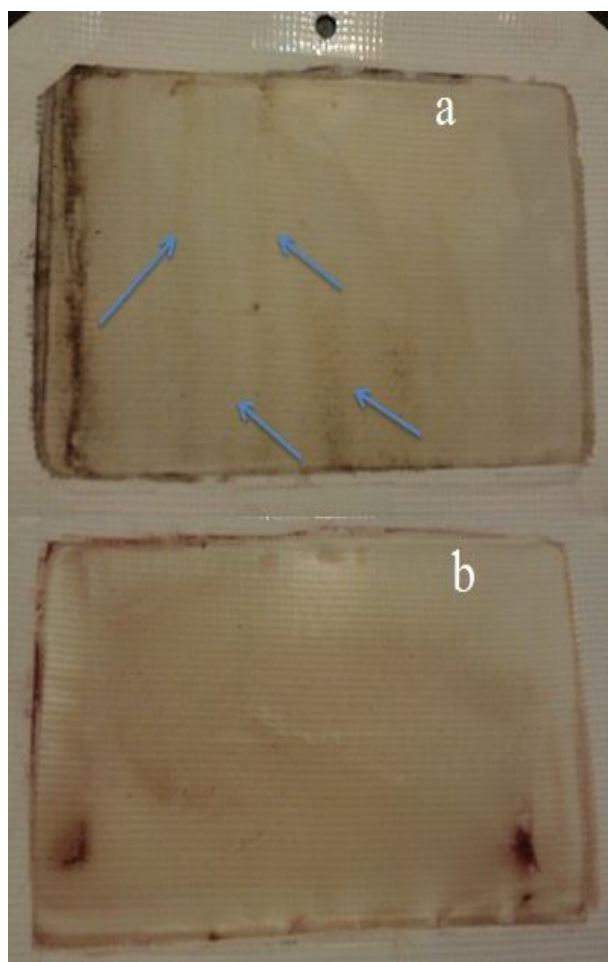

Fig. 8. Membranes used to clarify pomegranate juice (a) with and (b) without using baffles on microfiltration unit.

Discussion

Evaluation of the effect of baffle configuration on the permeate flux showed that the results were according to the findings of some other researchers. Ahmad and Mariadas (16) observed increasing of permeate flux by application of helical baffles during the microfiltration of *saccharomyces cerevisiae* solutions. Also Ahmed et al. (11) obtained similar results during the application of circular baffles in the microfiltration unit.

Increasing the volumetric flow rate of the permeate with decreasing the distance between the baffles and the membrane surface was due to high turbulence of the feed flow between the baffles and the membrane surface, which can reduce cake formation on the membrane surface. However, Ahmad and Mariadas (16) found that increasing the number of turns per baffle length can initially increase and then decrease the permeate flux.

Increasing the feed velocity at the baffles can reduce the thickness of the cake layer on the membrane surface, and consequently, increase the permeate flux during the membrane clarification of pomegranate juice. Liu et al. (13) obtained similar results by application of baffles in the membrane processing of calcium carbonate suspension. They concluded that inserting the baffles can increase the

feed velocity and shear stress near the walls and the membrane surface.

CFD simulation of the effect of a baffle structure on the process efficiency in membrane clarification of pomegranate juice showed that:

- the permeate flux in the membrane module with a channel height of 2 cm, a baffle angle of 90° and 2 mm between the baffles and the membrane surface was more than in other geometries.
- Reducing the distance between the baffles and the membrane surface increased the permeate flux.
- Baffles created an eddy flow near the membrane surface in the flat-sheet module and reduced the total and cake-layer resistances.
- Baffles reduced the static pressure in the system, and consequently, decreased the driving force in the microfiltration unit.
- Increasing the number of baffles reduced the volumetric flow rate of permeate, and thus the system performance.
- Increasing the number of baffles could increase the reduction of both static pressure and feed velocity.

Financial disclosure

The authors declared no financial interest.

Funding/Support

The study did not receive any financial support.

References

1. Mirsaedghazi H, Mousavi SM, Emam-Djomeh Z, Rezaei K, Aroujalian A, Navidbakhsh M. Comparison between ultrafiltration and microfiltration in the clarification of pomegranate juice. *J Food Process Eng* 2012; 35: 424.
2. Echavarría AP, Torras C, Pagán J, Ibarz A. Fruit juice processing and membrane technology application. *Food Eng Rev* 2011; 3: 136.
3. Mirsaedghazi H, Emam-Djomeh Z, Mousavi SM, Aroujalian A, Ahmadvaniha R, Shafiee A. Effect of membrane clarification on the physicochemical properties of pomegranate juice. *Int J Food Sci Technol* 2010; 45: 1457.
4. Hojjatpanah G, Emam-Djomeh Z, Kalbasi Ashtari A, Mirsaedghazi H, Omid M. Evaluation of the fouling phenomenon in the membrane clarification of black mulberry juice. *Int J Food Sci Technol* 2011; 46: 1538.
5. Nourbakhsh H, Alemi A, Emam-Djomeh Z, Mirsaedghazi H. Effect of processing parameters on fouling resistances during microfiltration of red plum and watermelon juices: a comparative study. *J Food Sci Technol* 2014; 51: 168.
6. Mirsaedghazi H, Emam-Djomeh Z, Mousavi SM, Aroujalian A, Navidbakhsh M. Changes in blocking mechanisms during membrane processing of pomegranate juice. *Int J Food Sci Technol* 2009; 44: 2135.
7. Ren HW, Zhang Y. Applications of computational fluid dynamics (CFD) in the food industry. *Adv Mat Res* 2011; 236-238: 2273.
8. Xia B, Sun DW. Applications of computational fluid dynamics (CFD) in the food industry: A review. *Comput Electronic Agr* 2002; 34(1-3): 5.
9. Norton T, Sun DW. Computational fluid dynamics (CFD)-an effective and efficient design and analysis tool for the food industry: A review. *Trends Food Sci Technol* 2006; 17(11): 600.
10. Pak A, Mohammadi T, Hosseinalipour SM, Allahdini V. CFD modeling of porous membranes. *Desalination* 2008; 222: 482.
11. Ahmed S, Seraji MT, Jahedi J, Hashib MA. Application of CFD for simulation of a baffled tubular membrane. *Chem Eng Res Design* 2012; 90(5): 600.
12. Jafarkhani M, Moraveji MK, Davarnejad R, Moztarzadeh F, Mozafari M. Three-dimensional simulation of turbulent flow in a membrane tube filled with semi-circular baffles. *Desalination* 2012; 294: 8.
13. Liu Y, GHe G, Liu X, Xiao G, Li B. CFD simulations of turbulent flow in baffle-filled membrane tubes. *Sep Purif Technol* 2009; 67(1): 14.
14. Rahimi M, Madaeni SS, Abbasi K. CFD modeling of permeate flux in cross-flow microfiltration membrane. *J Membrane Sci* 2005; 255(1-2): 23.
15. Mirsaedghazi H, Emam-Djomeh Z, Mousavi SM, Navidbakhsh M. Modelling the membrane clarification of pomegranate juice with computational fluid dynamics. *Eur Food Res Technol* 2011; 232: 671.
16. Ahmad AL, Mariadas A. Baffled microfiltration membrane and its fouling control for feed water of desalination. *Desalination* 2004; 168(0): 223.